

Master of Applied Sciences and Engineering Mechanical Engineering



Speciality Computational engineering

Description of the diploma

This Master's program is aimed at training graduates in engineering and science with the skills required to understand, and use, applied mathematical modelling and scientific computing. It provides a detailed insight into industrial-environmental modelling problem and numerical software. This programme also wants to demonstrate how computational engineering is used effectively in solving real-world problems.

This Masters program is composed of two years training (four semesters). The first year (M1) is devoted to basic computational methods applied to the fluid and solid mechanics. It gives the basis for mathematical and numerical tools supported by projects for real applications. The second year (M2) is composed of a first semester, which is focused on the training with industrial codes. The second semester of M2 is devoted to the master thesis (16 weeks in industry or research laboratories) and the final examination.

Research association (in Strasbourg)

Institut de Mécanique des Fluides et des Solides de Strasbourg, Université de Strasbourg, CNRS

Laboratoire du Génie de la Conception, INSA de Strasbourg

Laboratoire d'Hydrologie et de Géochimie de Strasbourg, Université de Strasbourg, CNRS

Professional objectives

Numerical modelling for industrial applications is a rapidly growing discipline, which brings together the power of computers and the biological, chemical and physical sciences. Computer based simulations and their related visualisations play a key role in industrial applications, environmental or biomechanical investigations. This master aims to train students with research and development skills through projects, which will have industrial and/or academic significance. During this master program, students will acquire the backgrounds in computational engineering, which will allow applying for jobs in industry as well as in research laboratories where computational work is needed.

Prerequisite

For the first year (M1) :

Students with a Bachelor degree (L3 level in the French system : 3 years college degree) in Engineering Sciences (mechanical, civil or materials), mathematics or physics, can be accepted in the first year of the Master. A sufficient knowledge of the English language is necessary. Knowledge of the French language will be appreciated but is not necessary. A specific commission, who will make the final decision for acceptance or rejection, will evaluate the applications.

For the second year (M2) :

The second year is the logical continuation of the first year but is open to students who have a good engineering background such as students from French schools of engineers (INSA, ENSI ...) or students with equivalent background. A specific commission, who will make the final decision for acceptance or rejection, will evaluate the applications.

Semestre 1**30 CREDITS****M1****Semestre 2****30 CREDITS****10 UE**

- Informatics (Fortran 90, MATLAB) 3 ECTS
- Informatics project 3 ECTS
- Mathematical methods for physics 3 ECTS
- Continuum Mechanics 3 ECTS
- Elemental numerical methods 1 3 ECTS
- Elemental numerical methods 2 3 ECTS
- Computational fluid mechanic, incompressible flows 3 ECTS
- Constitutive laws for computational mechanics 3 ECTS
- Computational plasticity 3 ECTS
- Project M1- S1 3 ECTS

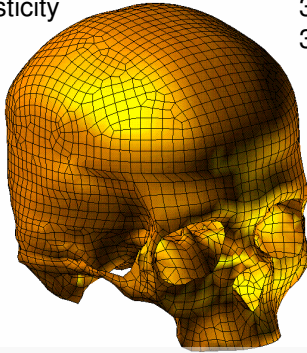
**10 UE**

- Spectral analysis 3 ECTS
- Advanced Numerical Methods 3 ECTS
- Optimization and inverse methods 3 ECTS
- Computational Fluid Dynamic, compressible flows 3 ECTS
- Multiscale modelling 3 ECTS
- Computational dynamics 3 ECTS
- Computational analysis for statistical methods 3 ECTS
- Measurement and Identification 3 ECTS
- Project M1- S2 3 ECTS
- UE free 3 ECTS

Semestre 3**30 CREDITS****M2****Semestre 4****30 CREDITS****10 UE**

- Applied Computational Engineering for heat and mass transfer 3 ECTS
- Applied Computational Engineering for materials and structures 3 ECTS
- Visualization and grid generation 3 ECTS
- Advanced utilization of CFD code 3 ECTS
- Advanced utilization of computational solid mechanics codes 3 ECTS
- Advanced computation in biomechanics 3 ECTS
- Development and utilization of simulation statistical methods 3 ECTS
- Free software in CFD and CSM 3 ECTS
- Management project 3 ECTS
- UE free 3 ECTS

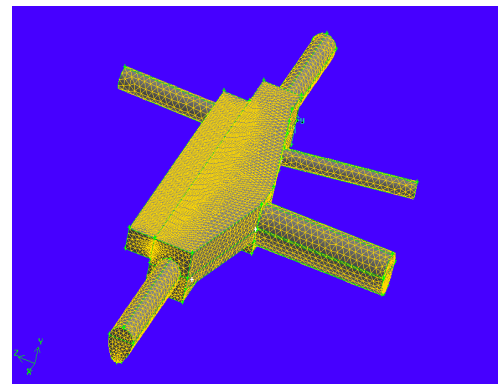
● Master Thesis**30 ECTS****Contacts / Renseignements**

Course Director :

Robert Mose

rmose@engees.u-strasbg.fr

Master Director :

Christian Gauthier

christian.gauthier@unistra.fr

<http://www-ingenierie.u-strasbg.fr/>

UFR Physique & Ingenierie, Scolarity, Meinau Campus

15-17, rue du Maréchal Lefebvre 67100 Strasbourg

Tel : 03 90 24 49 50 Fax : 03 90 24 49 72

Ingenierie-scolarity@u-strasbg.fr